

LONGITUDINAL LAP JOINT TREATMENT

FOR PROPOSED LANE WIDENINGS

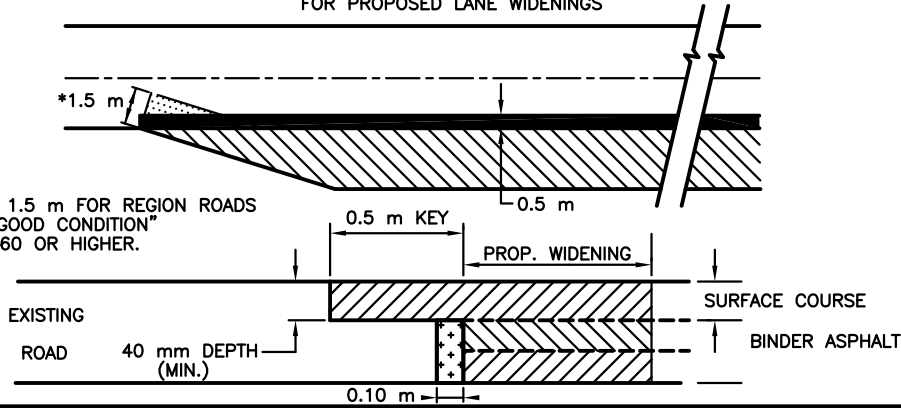

*MIN. 1.5 m FOR REGION ROADS IN "GOOD CONDITION" PCI 60 OR HIGHER.

NOTES

VERTICAL FACE AND BOTTOM OF KEY SHALL BE SWEEP CLEAN AND PAINTED WITH BITUMINOUS EMULSION.



REMOVE A MINIMUM OF 0.10 m OF EXISTING POORLY COMPACTED ASPHALT EDGE.

END TREATMENTS

FINAL LIFT OF ASPHALT SHALL BE PLACED IN FOLLOWING YEAR

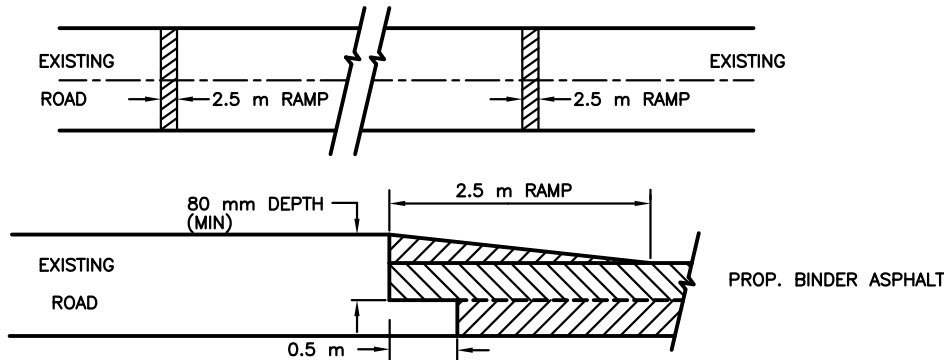

NOTES

ALL VERTICAL FACES OF JOINTS SHALL BE SWEEP CLEAN AND PAINTED WITH BITUMINOUS EMULSION PRIOR TO PAVING.

END TREATMENT LAP JOINT

TYPICAL END TREATMENT - FINAL OVERLAY

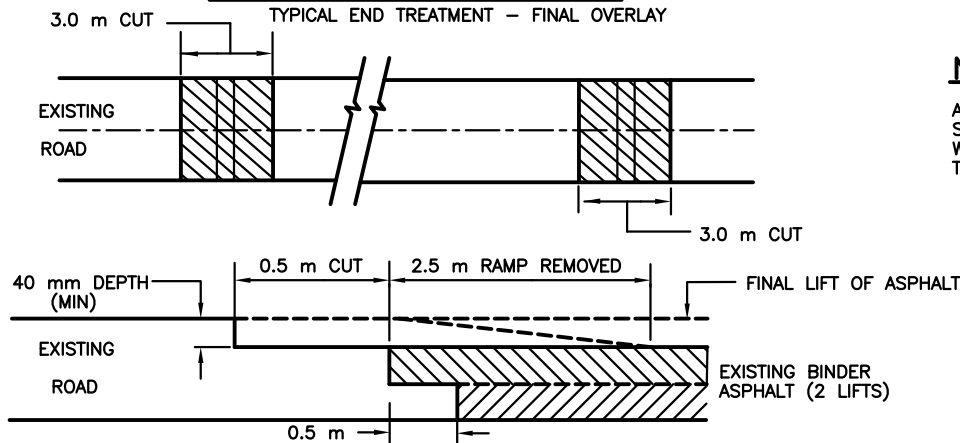

NOTES

ALL VERTICAL FACES OF JOINTS SHALL BE SWEEP CLEAN AND PAINTED WITH BITUMINOUS EMULSION PRIOR TO PAVING.

END TREATMENTS

ASPHALT OVERLAY SECTIONS

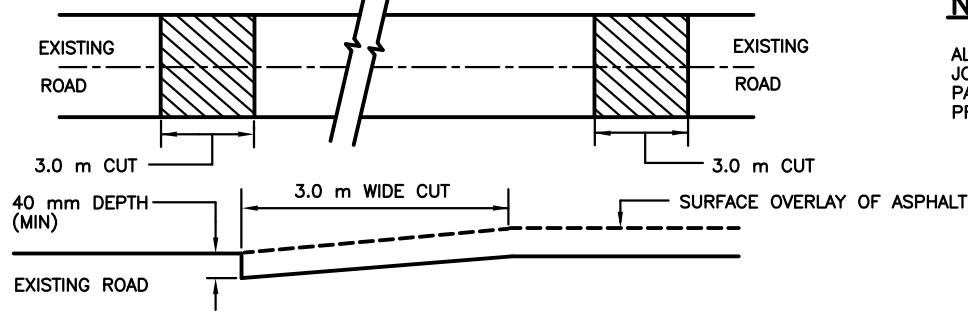

NOTES

ALL VERTICAL FACES OF END JOINTS SHALL BE SWEEP CLEAN AND PAINTED WITH BITUMINOUS EMULSION PRIOR TO PAVING.

ALL DIMENSIONS IN MILLIMETRES EXCEPT WHERE NOTED.



WORKS DEPARTMENT

PAVEMENT JOINT TREATMENT

DWG. DATE: 1986 04

REVISION NO.: 7

REV. DATE: 2013 04

SCALE: N.T.S.

S-301.010