

PLAN

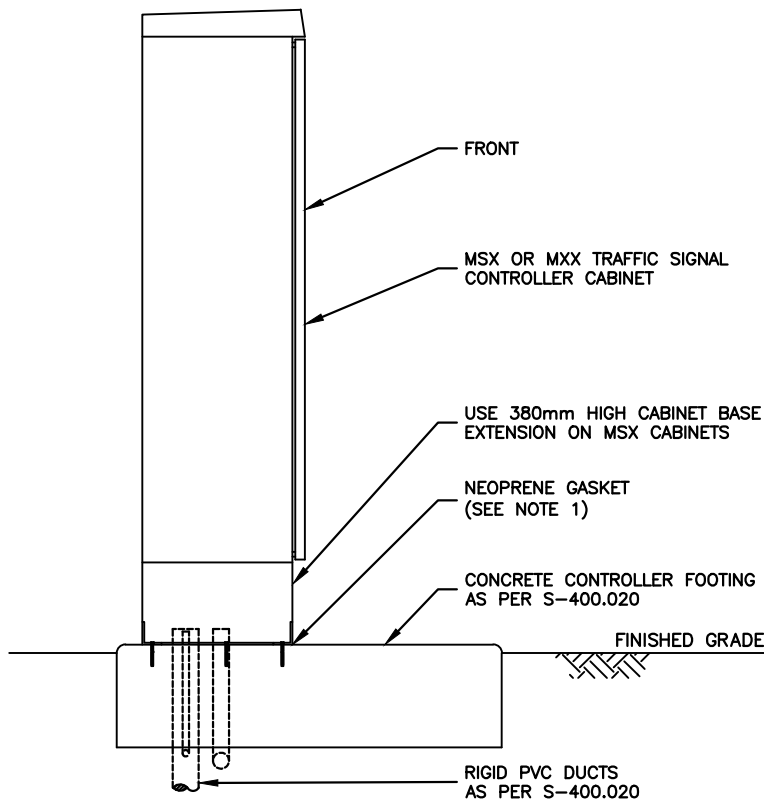

SECTION 'A-A'

NOTES:

1. CABINETS TO BE SEALED AROUND BOTTOM PERIMETER WITH A 10mm THICK BY 65mm WIDE NEOPRENE GASKET. GASKET TO HAVE A DUROMETER HARDNESS OF 45 AND TO BE PROVIDED WITH ADHESIVE BACKING FOR ATTACHMENT TO THE CABINET. (SEE DETAIL 'A')
2. CABINETS TO BE ACCURATELY ALIGNED AND SECURED TO THE CONCRETE CONTROLLER BASE AS SHOWN IN DETAIL 'A'. SQUARE WASHER MAX. HOLE DIA. IS 18mm BUT MUST BE ACCOMPANIED WITH A STAINLESS STEEL WASHER WITH 14mm DIA. HOLE.
3. FOR NUMBERS, SIZES AND ORIENTATION OF CONDUITS ENTERING CONCRETE PAD, REFER TO S-400.020.
4. FOR LOCATION AND ORIENTATION OF CABINET, CONCRETE PAD, REFER TO CONTRACT DRAWINGS.
5. CABINETS SHALL BE PICKED UP AT THE TRAFFIC OPERATIONS CENTRE LOCATED AT 101 CONSUMERS DR.

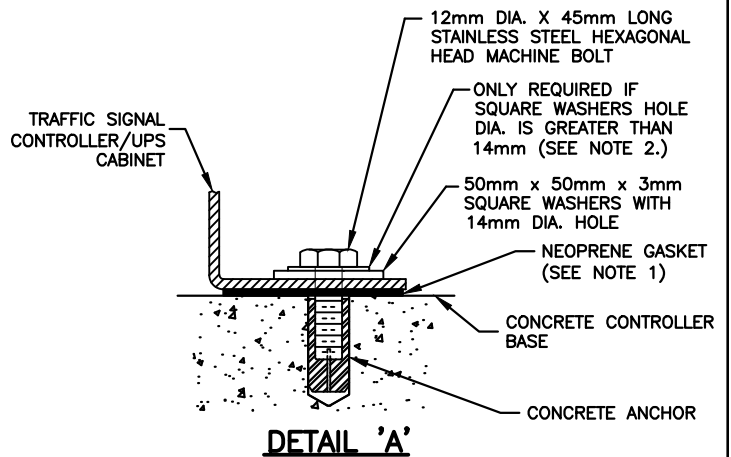

ALL DIMENSIONS IN MILLIMETRES EXCEPT WHERE NOTED.



WORKS DEPARTMENT

**TRAFFIC SIGNAL CONTROLLER/UPS CABINET
INSTALLATION ON CONCRETE FOOTING**

DWG. DATE:	2007 07
REVISION NO.:	5
REV. DATE:	2021 04
SCALE:	N.T.S.

S-410.081